



**DEPARTMENT OF MECHANICAL ENGINEERING  
KIIT UNIVERSITY  
BHUBANESWAR  
INSTRUCTION SHEET  
APPLIED MECHANICS & DYNAMICS LAB.  
WHEEL AND DIFFERENTIAL AXLE.**

\*\*\*\*\*

**1. AIM:**

To determine Mechanical Advantage (M.A), Velocity Ratio (V.R), efficiency ( $\eta$ ) and to check Law of machine of a wheel and differential axle.

**2. EQUIPMENT REQUIRED.**

- 2.1 wheel and differential axle.
- 2.2 Weights.
- 2.3 Vernier caliper
- 2.4 Rope.
- 2.5 Effort pan & hanger.

**3. DESCRIPTION ABOUT MACHINE:**

Radius of pulley (R) = 14.95 cm  
 Radius of larger axle ( $r_1$ ) = 6.61 cm  
 Radius of smaller axle ( $r_2$ ) = 3.97 cm

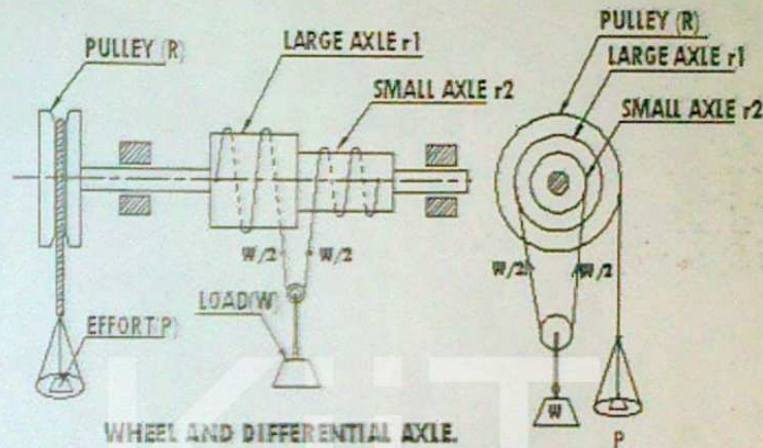

**4. THEORY.**

The wheel and differential axle is an improvement over wheel and axle. In this machine the axle is made of two parts of radius ( $r_1$ ) & ( $r_2$ ). One end of the rope is fixed on the smaller axle and wound round it and then wound round the larger axle. The rope suspended from the axle will carry the load (W) to be lifted. One end of the another rope is fixed to the larger wheel of radius (R) and wound round it, in such a way that when it gets un-winded the rope on the larger axle will be wound. The effort is applied at the end of the rope suspended from the wheel.

**4.1 MECHANICAL ADVANTAGE:**

It is defined as the ratio of weight lifted (W) to the effort (P) applied.

$$M.A = W/P$$

**4.2 VELOCITY RATIO:**

So under equilibrium condition of wheel and differential axle, the summation of moment will be zero

$$PR + W/2 \cdot r_2 - W/2 \cdot r_1 = 0$$

$$PR = W/2(r_1 - r_2)$$

$$W/P = 2R/(r_1 - r_2)$$

So,  $M.A = 2R/(r_1 - r_2)$

We know under ideal condition  $M.A = V.R$

$$\begin{aligned}\text{So, } V.R &= 2R/(r_1 - r_2) \\ &= 2\pi R/(2\pi r_1/2 - 2\pi r_2/2)\end{aligned}$$

#### 4.3 EFFICIENCY( $\eta$ ):

( $\eta$ ) = output / input

$$\begin{aligned}&= \frac{\text{load lifted} \times \text{distance through which load is lifted}}{\text{effort applied} \times \text{distance covered by the effort}} \\ &= \frac{W \times X}{P \times Y} = \frac{W/P}{Y/X} = \frac{M \cdot A}{V \cdot R}\end{aligned}$$

#### 4.4 LAW OF MACHINE

It provides the relationship between effort and the corresponding load lifted by the application of effort.

$$P = MW + C \text{ ----- (1)}$$

where P = Effort applied

M = Const. called coefficient of friction which equal to slope of the line.

W = Load lifted.

C = Const. called machine friction.

#### 5. PROCEDURE:

- 5.1 Measure the radius of wheel R larger axle  $r_1$  & smaller axle  $r_2$ .
- 5.2 Measure machine friction 'C' at no load condition.
- 5.3 Take ten readings taking different loads and efforts.
- 5.4 Calculate efficiency in each time and calculate mean efficiency.
- 5.5 Draw the graph between load Vs effort.
- 5.6 Determine the coefficient of friction 'M' from the graph.
- 5.7 By putting the values of 'M' and 'C' in equation (1) we determine from which the law of machine, we can find out the amount of effort required to lift any load.

#### 6. OBSERVATION:

Sl no	'C' Machine friction	'M' Coefficient Of Machine friction	V.R	W in (kg)	P in (kg)	Mechanical Advantage. W/P	$\eta$ efficiency	Mean ( $\eta$ )

#### 7. CALCULATION:

#### 8. CONCLUDING REMARKS: